

LL-509YGM2E-003

DATA SHEET

QC :

ENG :

Prepared By:

Part No.	LL-509YGM2E-003	Spec No.	S/N-01062720D	Page	1 of 5
----------	-----------------	----------	---------------	------	--------

Features

- ◆ Standard T-1 3/4 diameter package
- ◆ Wide viewing angle
- ◆ General purpose leads
- ◆ Reliable and rugged

Package Dimension:

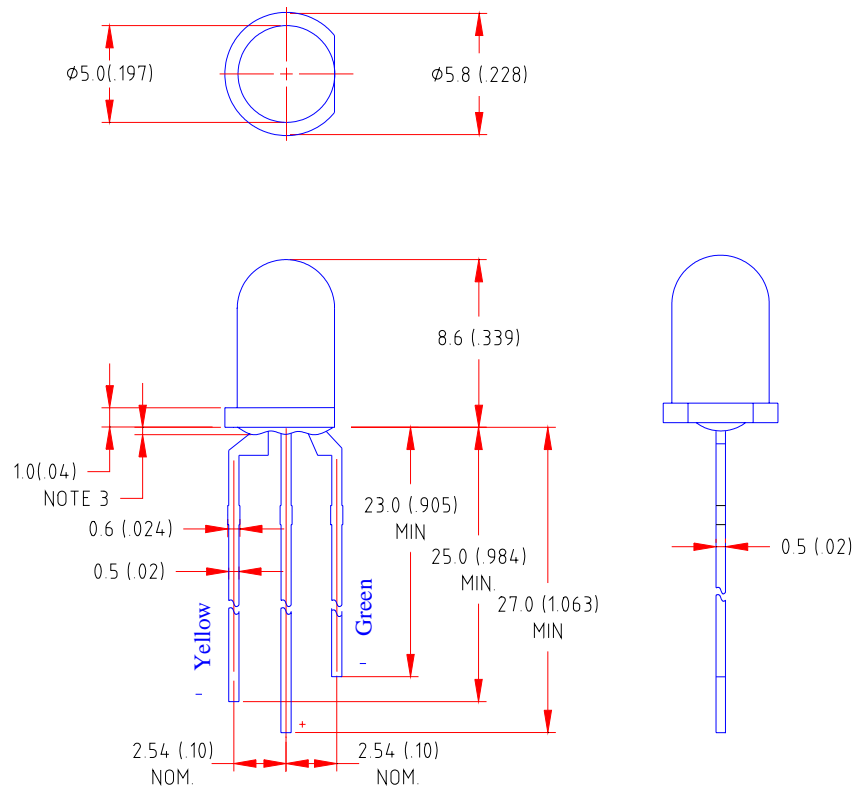

Part NO.	Lens Color	Source Color
LL-509YGM2E-003	White Diffused	Yellow & Green

Notes:

1. All dimensions are in millimeters (inches).
2. Tolerance is ± 0.25 (.010") mm unless otherwise noted.
3. Protruded resin under flange is 1.0mm (.04") max
4. Lead spacing is measured where the leads emerge from the package.
5. Specifications are subject to change without notice

Absolute Maximum Ratings at Ta=25

Parameter	MAX.	Unit
Power Dissipation	100	mW
Peak Forward Current (1/10 Duty Cycle, 0.1ms Pulse Width)	100	mA
Continuous Forward Current	50	mA
Derating Linear From 50	0.4	mA/
Reverse Voltage	5	V
Operating Temperature Range	-40 to +80	
Storage Temperature Range	-40 to +80	
Lead Soldering Temperature [4mm(.157") From Body]	260 for 5 Seconds	

Electrical Optical Characteristics at Ta=25

Parameter	Symbol	Emitting Color	Min.	Typ.	Max.	Unit	Test Condition
Luminous Intensity	I _v	Yellow	0.6	2.5	6	mcd	I _f =20mA Note 1
		Green	1	4	8		
Viewing Angle	2 _{1/2}	Yellow	50	60	70	Deg	Note 2
		Green	50	60	70		
Peak Emission Wavelength	p	Yellow	584	588	592	nm	Measurement @Peak
		Green	560	568	568		
Dominant Wavelength	d	Yellow	583	590	596	nm	Note 3
		Green	564	570	576		
Spectral Line Half-Width		Yellow	30	35	40	nm	
		Green	25	30	35		
Forward Voltage	V _F	Yellow	1.6	2.1	2.6	V	I _f =20mA
		Green	1.7	2.2	2.6		
Reverse Current	I _R	Yellow			100	μA	V _r =5V
		Green					

Note:

- 1.Luminous intensity is measured with a light sensor and filter combination that approximates the CIE eye-response curve.
2. _{1/2} is the off-axis angle at which the luminous intensity is half the axial luminous intensity.
- 3.The dominant wavelength (d) is derived from the CIE chromaticity diagram and represents the single wavelength which defines the color of the device.

Typical Electrical / Optical Characteristics Curves
 (25 Ambient Temperature Unless Otherwise Noted)

Spectral Radiance **Green Peak @ 568nm**
 Yellow Peak @ 588nm

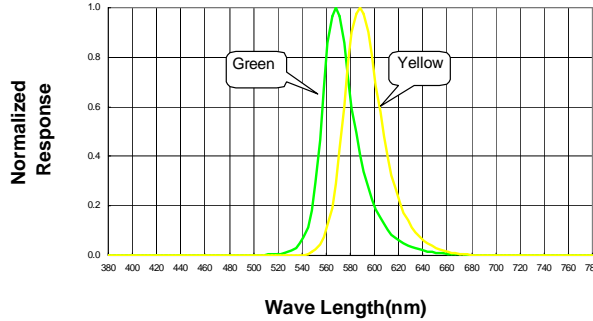

Forward Current vs Forward Voltage

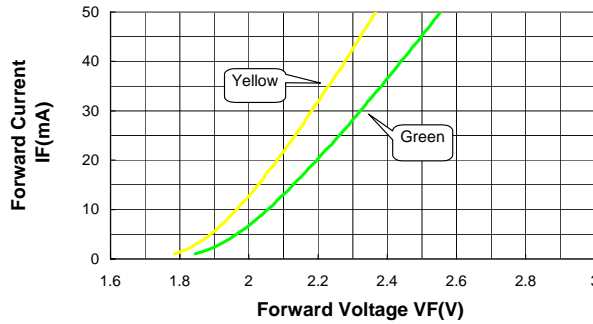

Relative Luminous Intensity vs Forward Current

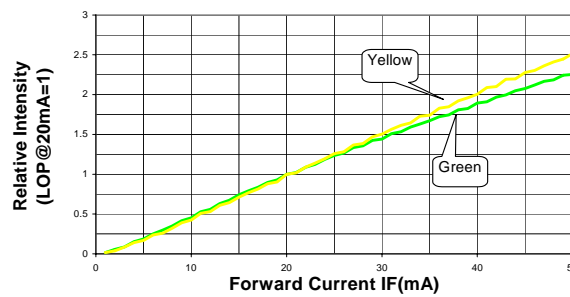

Beam Pattern

