

LL-509SGM2E-004

DATA SHEET

QC :

ENG :

Prepared By:

Part No.	LL-509SGM2E-004	Spec No.	S/N-02081206D	Page	1 of 5
----------	-----------------	----------	---------------	------	--------

Features:

- ◆ High intensity
- ◆ Standard T-1 3/4 diameter package
- ◆ General purpose leads
- ◆ Reliable and rugged

Package Dimensions:

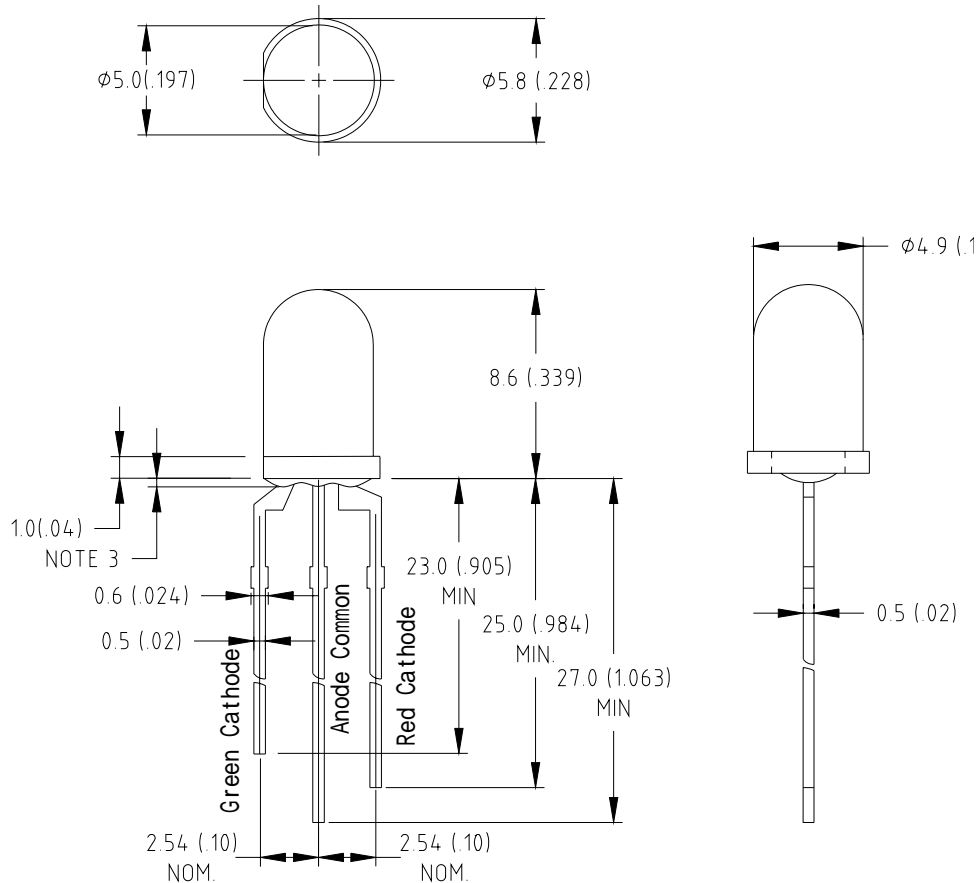

Part NO.	Chip Material		Lens Color	Source Color
LL-509SGM2E-004	Red	Green	White Diffused	Red & Green
	AlGaAs	GaP		

Notes:

1. All dimensions are in millimeters (inches).
2. Tolerance is ± 0.25 mm (.010") unless otherwise noted.
3. Protruded resin under flange is 1.0mm (.04") max.
4. Lead spacing is measured where the leads emerge from the package.
5. Specifications are subject to change without notice.
6. This data-sheet only valid for six months.

Absolute Maximum Ratings at Ta=25

Parameter	MAX.	Unit
Power Dissipation	100	mW
Peak Forward Current (1/10 Duty Cycle, 0.1ms Pulse Width)	100	mA
Continuous Forward Current	35	mA
Derating Linear From 50	0.4	mA/
Reverse Voltage	5	V
Operating Temperature Range	-40 to +80	
Storage Temperature Range	-40 to +80	
Lead Soldering Temperature [4mm(.157") From Body]	260 for 5 Seconds	

Electrical Optical Characteristics at Ta=25

Parameter	Symbol	Emitting Color	Min.	Typ.	Max.	Unit	Test Condition
Luminous Intensity	I _v	Green	25	50	100	mcd	I _f =20mA Note 1
		Red	20	40	80		
Viewing Angle	2 _{1/2}	Green	50	60	70	Deg	Note 2
		Red	50	60	70		
Peak Emission Wavelength	p	Green	563	568	573	nm	Measurement @Peak
		Red	655	660	665		
Dominant Wavelength	d	Green	566	572	576	nm	Note 3
		Red	635	640	645		
Spectral Line Half-Width		Green	25	30	35	nm	
		Red	20	25	30		
Forward Voltage	V _F	Green	1.7	2.2	2.6	V	I _f =20mA
		Red	1.5	1.85	2.4		
Reverse Current	I _R	Green	---	---	100	μA	V _R =5V
		Red					

Notes:

- 1.Luminous intensity is measured with a light sensor and filter combination that approximates the CIE eye-response curve.
2. _{1/2} is the off-axis angle at which the luminous intensity is half the axial luminous intensity.
- 3.The dominant wavelength (d) is derived from the CIE chromaticity diagram and represents the single wavelength which defines the color of the device.

Typical Electrical / Optical Characteristics Curves
 (25 Ambient Temperature Unless Otherwise Noted)

Spectral Radiance Green Peak @ 568nm
 Red Peak @ 660nm

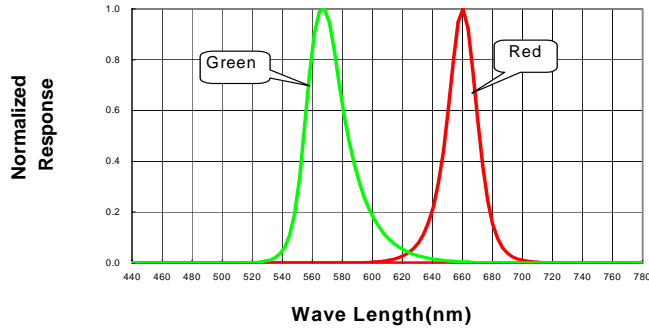

Forward Current vs Forward Voltage

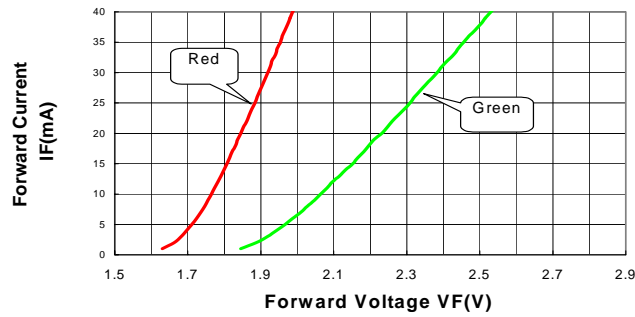

Relative Luminous Intensity vs Forward Current

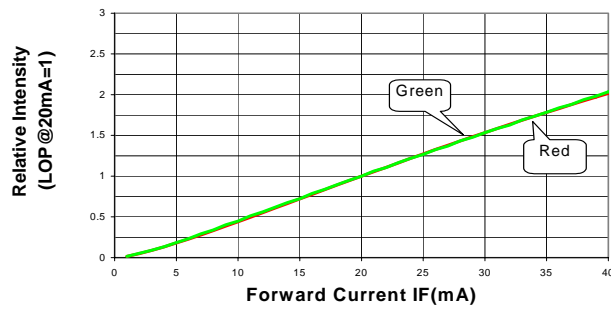

Beam Pattern

