

LL-1003YC1L-003

DATA SHEET

CHECK BY:

MODIFIED BY: 潘冬梅

DATE: 2000/07/07

Part No.	LL-1003YC1L-003	Spec No.	S/N-00070709S	Page	1 of 5
----------	-----------------	----------	---------------	------	--------

Features

- ◆ High intensity
- ◆ Popular 10mm bullet head type diameter package
- ◆ Selected minimum intensities
- ◆ Wide viewing angle
- ◆ General purpose leads
- ◆ Reliable and rugged

Package Dimension:

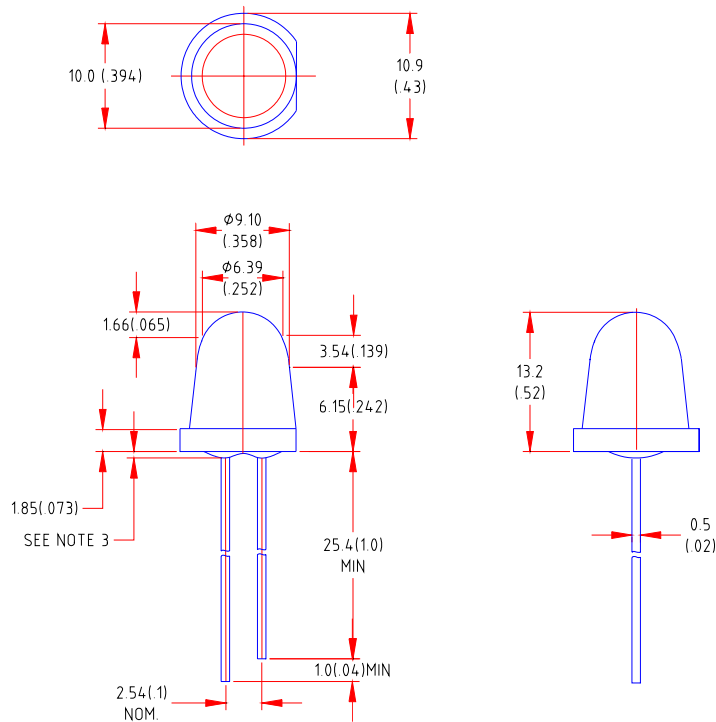

Part NO. LL-	Lens Color	Source Color
1003YC1L-003	Water Clear	Yellow

Notes:

1. All dimensions are in millimeters (inches).
2. Tolerance is ± 0.25 (.010") mm unless otherwise noted.
3. Protruded resin under flange is 1.0mm (.04") max
4. Lead spacing is measured where the leads emerge from the package.
5. Specifications are subject to change without notice

Absolute Maximum Ratings at Ta=25

Parameter	LL-1003YC1L-003	Unit
Power Dissipation	100	mW
Peak Forward Current (1/10 Duty Cycle, 0.1ms Pulse Width)	100	mA
Continuous Forward Current	20	mA
Derating Linear From 50	0.4	mA/
Reverse Voltage	5	V
Operating Temperature Range	-40 to +80	
Storage Temperature Range	-40 to +80	
Lead Soldering Temperature [4mm(.157") From Body]	260 for 5 Seconds	

Electrical Optical Characteristics at Ta=25

Parameter	Symbol	Min.	Typ.	Max.	Unit	Test Condition
Luminous Intensity	I _v		6800		mcd	I _f =20mA Note 1
Viewing Angle	2 _{1/2}		10		Deg	Note 2
Peak Emission Wavelength	ρ		592		nm	Measurement @Peak
Dominant Wavelength	d		589		nm	Note 3
Spectral Line Half-Width			18		nm	
Forward Voltage	V _F		2.0	2.6	V	I _f =20mA
Reverse Current	I _R			100	μA	V _R =5V

Note:

- 1.Luminous intensity is measured with a light sensor and filter combination that approximates the CIE eye-response curve.
2. _{1/2} is the off-axis angle at which the luminous intensity is half the axial luminous intensity.
- 3.The dominant wavelength, d is derived from the CIE chromaticity diagram and represents the single wavelength which defines the color of the device.

Typical Electrical / Optical Characteristics Curves
 (25 Ambient Temperature Unless Otherwise Noted)

